

# SolarComm Universal Modem with GPS

## Connect and Talk to NTCIP Boards from any Manufacturer

Here's a product designed to make your life easier. SolarComm Universal lets you talk to any NTCIP-compatible message boards - regardless of manufacturer - and see their location and change messages from your office using our Command Center software.

Its a modem and GPS package with free communications software, and you can choose to rent or own the hardware:

- No need to buy, install and maintain modems
- No reason to manage multiple manufacturers' control software
- No longer waste time traveling to the work zone to change messages
- Never have boards shut down due to low battery voltage

It's simple, reliable communication to all your NTCIP-compatible boards - all makes and models from any manufacturer.

SolarComm Universal is the conduit through which you can communicate with any NTCIP device, regardless of who manufactured it. And, because the communication is on a private network, it's more secure than public IP addressed modems.



## Technical Specifications

### SOLARCOMM UNIVERSAL INCLUDES:

- Ethernet Cable
- Serial Cable
- Power wire
- Combo Cell/GPS Antenna (roof mount)

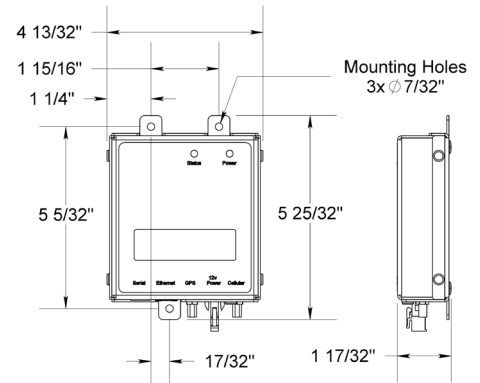

### Interfaces:

Ethernet and RS 232 Serial

### Power:

Input Voltage 9 - 24 VDC  
 Maximum current: 1.5 amps

### Operating Temperature:

-40 to +85° C (-40 to +185° F)

### Relative Humidity:

20 to 98% non-condensing

## How SolarComm Universal Works

SolarComm Universal plugs into the controller of any NTCIP-compatible message board, and allows you to locate, monitor and program that board securely and inexpensively.

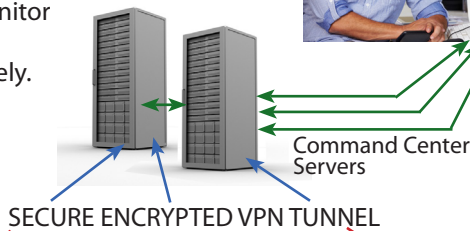

[www.solartechology.com](http://www.solartechology.com)  
 800-475-5442