



As Reliable as the Sun

### USES AND ADVANTAGES

This "Silent Messenger IV" is a small-sized message board, sized right for residential areas, for city or county roads, or anywhere a smaller footprint is preferred. Available in 3 panel sizes and a variety of matrices, this message board is powered by a combination of solar panels and batteries.

Radar can be easily added to communicate a simple message plus vehicle speed to calm traffic.

### OPTIONAL REMOTE COMMUNICATIONS AND GPS TRACKING!

Looking to communicate with your Message Board remotely? With this option, the unit comes with a GPS receiver, cellular transceiver, and **FREE lifetime cellular service\***. Use with SolarTech's Command Center software, which allows you to track your equipment using the built-in cellular transceiver and GPS system.

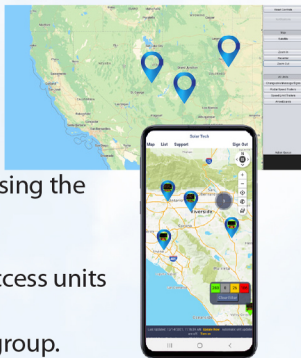

Manage your fleet from your laptop, PC or smartphone... without leaving your desk! Access units from a map or list.

Control units individually or broadcast to a group. You can build a message library, share messages between boards, schedule messages and more. Get automatic email notifications when a message changes, if the battery voltage is low, if a pixel fails, or the unit moves.

No more misplaced equipment... fewer problems... less downtime!

# Silent Messenger IV Message Board Small-Sized



### EASY-TO-USE CONTROLLER

The touch-screen controller needs no manual - it's that easy to use! Includes:

- Password protection
- Intuitive icons for ease of use
- Scheduling capability
- Fully networkable
- NTCIP version 3 compatible



#### PANEL SIZES

- 60" wide x 30" high
- 78" wide x 30" high
- 78" wide x 33" high



60' x 30"  
19mm pixel pitch



60' x 30"  
38mm pixel pitch

# Silent Messenger IV Message Board

## DISPLAY PANEL

Panel Size .....	60" wide x 30" high (152 cm x 76 cm) 78" wide x 30" high (198 cm x 76 cm) 78" high x 33" wide (198 cm x 84 cm)
Panel Construction .....	All aluminum, modular construction
Pixel Size .....	1.5" x 1.5" (38 mm x 38 mm) 0.75" x 0.75" (19 mm x 19 mm)
Number of Fonts .....	Twelve (12)
Character Height .....	7.5" to 30" (19 cm to 76 cm) - 38 mm 3.75" to 30" (10 cm to 76 cm) - 19 mm
Graphics Capability .....	Full matrix with animation
Display Technology .....	LED (amber, 592 nm)
Display Life Expectancy .....	10 years typical
Lifting Mechanism .....	1,000 lb. capacity winch & cable
Viewing Angle .....	>60°
Sign Panel Height (Operating) ...	7 feet (214 cm) to bottom of sign panel

## TRAILER

Length Overall .....	117" (298 cm) - towing / 75" (191 cm) - deployed/stored
Width Overall .....	60" (152 cm) or 78" (198 cm)
Width Across Fenders .....	56" (142 cm)
Height Traveling .....	90" (229 cm)
Height Operating .....	129" (328 cm)
Ground Clearance .....	13" (33 cm)
Weight .....	1,200 lbs. (544 kg) approx. (maximum)
Coupler (Class III) .....	2" (50 mm) ball or 2-1/2" (64 mm) pintle ring
Axle/Suspension .....	Torq-Flex - independent

## MEGA-TECH CONTROL CONSOLE

Console Circuitry .....	Ultra-low power solid state
Console Touchscreen .....	Weather-resistant, backlit, full-color GUI, intuitive icon-driven, multi-lingual: five international languages
Programming Software .....	Proprietary, field upgradable (for units not connected to Command Center)
Message Capacity .....	Pre-programmed and user-programmed: > 250 each
Time-Date Control .....	Real-time clock/calendar (365 day)
Message Display Time .....	User-selectable (0.1 to 99 seconds)
Display Update Time .....	Instantaneous
Non-Volatile Memory .....	16 GB Micro SD card
Password Protection .....	User-selectable, multi-level
Operator Interface .....	Easy-to-use icons (no manual required)
Connectivity .....	Networkable (wired or wireless) and NTCIP compatible (Ethernet & RS-232)

## ENERGY SOURCE

Operating Voltage .....	12 volts DC (nominal)
Battery Type .....	6 volt heavy duty, deep cycle (GC-2)
Number of Batteries .....	Four (4) standard lead acid (flooded)
Battery Bank Capacity .....	520 amp hours
Battery Status Indicator .....	Displays full-charge, normal and, low battery condition
Solar Array Construction .....	Top-mounted solar panels in aluminum frame
Solar Array Power Output .....	Standard - 160 watt (nominal)
Solar Charge Controller .....	Automatic, temperature compensated, MPPT (Maximum Power Point Tracking)



SCAN ME



**SOLAR TECHNOLOGY, INC.**  
7620 Cetronia Rd. Allentown, PA 18106  
Phone: 800-475-5442 or 610-391-8600

P/N 500-010-040 Rev. L 2022



## OPTIONS AND UPGRADES

### SOLAR ARRAY OPTION

• 220 watt • 270 watt • 330 watt

### REMOTE COMMUNICATIONS

Includes GPS receiver, cellular transceiver, and FREE cellular service\*. Remotely access and track your Message Board.

\* With this option, cellular service is provided free of charge, and is limited to carrier supported generational wireless technology.

### BATTERY UPGRADES

Type	Number	Capacity
Gel Cell or AGM	Four (4)	520 amp hour (maintenance-free)

### BATTERY CHARGER UPGRADES

• 45 amp, 120 volt AC • 55 amp, 120 volt AC

### BATTERY SECURITY OPTIONS

- Anti-theft steel security bolted to trailer
- Vandal-Proof Battery Box reinforced steel cage

### RADAR OPTIONS

Directional doppler K-Band, user-configured KPH or MPH  
Data collection and statistical analysis package included.

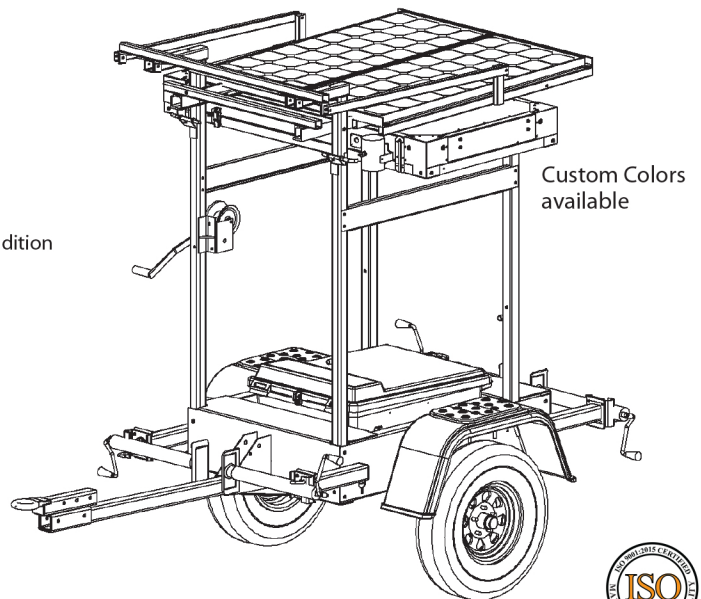

Custom Colors available



[www.solartechology.com](http://www.solartechology.com)

Made in the USA