



Silent Messenger II Message Board Mid-Sized

USES AND ADVANTAGES

The "Silent Messenger II" is a mid-sized message board. This rugged portable changeable message sign is designed to provide communications to improve traffic flow and safety in highway work zones.

The Silent Messenger II consists of a 92" w x 54" h sign panel with a 27 x 48 pixel full matrix LED display on a sturdy steel trailer, powered by a combination of solar panels and batteries. Choose from either a foldable or Lift and Rotate trailer.

OPTIONAL REMOTE COMMUNICATIONS AND GPS TRACKING!

With this option, the Message Board comes with a GPS receiver, cellular transceiver, and **FREE lifetime cellular service***. Use with SolarTech's Command Center software for remote communications - messages can be changed and managed remotely from a laptop, PC or a smartphone. No cellular charges!

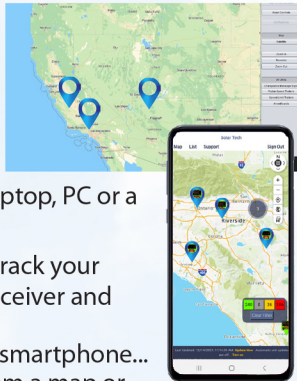

Command Center software allows you to track your equipment using the built-in cellular transceiver and GPS system.

Manage your fleet from your laptop, pc or smartphone... without leaving your desk! Access units from a map or list. Control units individually or broadcast to a group.

You can build a message library, share messages between boards, schedule messages and more.

Get automatic email notifications when a message changes, if the battery voltage is low, if a pixel fails, or the unit moves.

Keep tabs on your whole fleet. No more misplaced equipment... fewer problems... less downtime!



EASY-TO-USE CONTROLLER

The touch-screen controller needs no manual - it's that easy to use! Includes:

- Password protection
- Intuitive icons for ease of use
- Scheduling capability
- Fully networkable
- NTCIP version 3 compatible



Silent Messenger II Message Board

DISPLAY PANEL

Panel Size	92" x 54" (234 cm x 137 cm)
Pixel Array/Size	27 x 48 pixel array with 1.77" (45 mm) pitch
Character Height	12" to 38" (30.5 cm to 97 cm)
Panel Construction	All aluminum, modular construction
Panel Face	3/16" polycarbonate, non-glare
Characters per Line	Up to twelve (12)
Graphics Capability	Full matrix with full animation
Display Technology	LED (amber, 592 nm)
Display Brightness	> 10,000 candela per square meter
Display Life Expectancy	10 years typical
Viewing Angle	>60°

TRAILER

	Foldable Trailer	Lift & Rotate Trailer
Length Overall (operating)	112" (284 cm)	108" (274 cm)
Length Overall (towing)	112" (284 cm)	152" (386 cm)
Width Overall	92" (234 cm)	77" (196 cm)
Width Across Fenders	75" (191 cm)	77" (196 cm)
Height Traveling	92" (234 cm)	101" (257 cm)
Height Operating	142" (360 cm)	142" (360 cm)
Ground Clearance	13" (33 cm)	13" (33 cm)
Weight of MB II Panel	1,560 lbs (708 kg)	2,000 lbs (907 kg)
Coupler	2" (50 mm) ball or 2.5" (64 mm) pintle ring	2" (50 mm) ball or 3" (76 mm) pintle ring
Lifting Mechanism	1,000 lb. automatic brake, winch & cable	1,000 lb. electric linear actuator
Axle/Suspension	(for both) Torq flex, independent	

MEGA-TECH CONTROL CONSOLE

Console Circuitry	Ultra-low power solid state
Console Touchscreen	Weather-resistant, backlit, full-color GUI, intuitive icon-driven, multi-lingual
Programming Software	Proprietary, field upgradable for units not connected to Command Center
Message Capacity	Pre-programmed and user-defined (> 250 each)
Message Display Time	User-selectable (0.1 to 99 seconds)
Display Update Time	Instantaneous
Non-Volatile Memory	16 GB Micro SD card
Password Protection	User-selectable, multi-level
Operator Interface	Easy-to-use icons (no manual required)
Connectivity	Supports NTCIP version 3 via UDP/IP over Ethernet, and PMPP over RS-232; Units with Remote Communications Option: UDP/IP over the built-in cellular modem

ENERGY SOURCE

Operating Voltage	12 Volts DC (nominal)
Battery Type	6 Volt heavy duty, deep cycle (GC-2)
Number of Batteries	Four (4) standard lead acid (flooded)
Battery Bank Capacity	520 amp hours
Battery Status Indicator	Displays battery voltage, charging activity and low battery condition
Solar Array Construction	Top-mounted solar panels in aluminum frame
Solar Array Power Output	Standard 160 watt (nominal)
Solar Charge Controller	Automatic, temperature compensated, MPPT (Maximum Power Point Tracking)



SCAN ME



SOLAR TECHNOLOGY, INC.
7620 Cetronia Rd. Allentown, PA 18106
Phone: 800-475-5442 or 610-391-8600



OPTIONS AND UPGRADES

UPGRADES - LIFT & ROTATE TRAILER ONLY

- 30 x 48 pixel display panel at 1.77" (45 mm) pixel pitch; panel dimensions 59.5" x 92"
- 30 x 56 pixel display panel at 1.77" (45 mm) pixel pitch; panel dimensions 59.5" x 106"
- Tilt and Rotate Solar Arrays: • 160 watt • 220 watt • 330 watt

SOLAR ARRAY UPGRADES - BOTH TRAILERS

- Fixed Solar Arrays: • 220 watt • 270 watt • 330 watt

REMOTE COMMUNICATIONS

Includes GPS receiver, cellular transceiver, and FREE cellular service*. Remotely access and track your Message Board. *With this option, cellular service is provided free of charge, and is limited to carrier supported generational wireless technology.

BATTERY UPGRADES - BOTH TRAILERS

Type	Number	Capacity
Lead-Acid (flooded)	Six (6)	780 amp hour
	Eight (8)	1040 amp hour
Gel Cell or AGM (maintenance-free)	Four (4)	520 amp hour
	Six (6)	780 amp hour
	Eight (8)	1040 amp hour

BATTERY CHARGER OPTIONS - BOTH TRAILERS

- 45 amp, 120 volt AC • 55 amp, 120 volt AC • 90 amp, 120 volt AC

BRAKES - BOTH TRAILERS

- Hydraulic Surge Brakes (5,000 lb. Capacity)
- Electric Brakes

BATTERY SECURITY OPTION - BOTH TRAILERS

- Anti-theft steel security frame bolted to trailer
- Vandal-Proof Battery Box reinforced steel cage

RADAR OPTIONS - BOTH TRAILERS

- Directional doppler K-Band. User-configurable KPH or MPH. Data Collection and Statistical Analysis Package included.

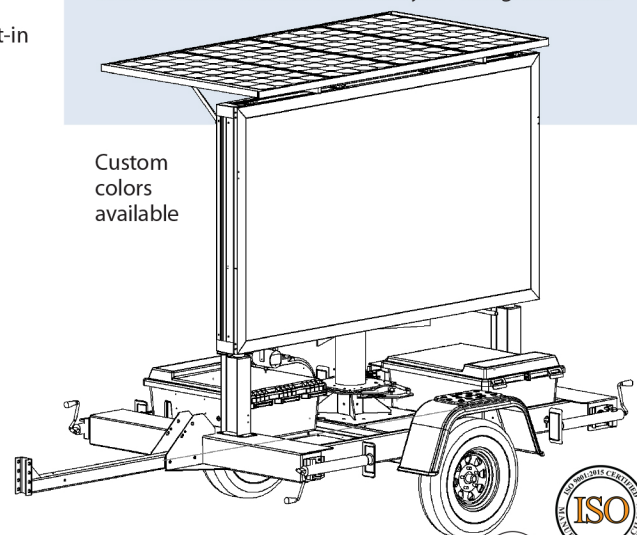

Custom colors available



www.solartechology.com

Made in the USA