

# Pivot Mount on Bed Rail Base with MBIII Board

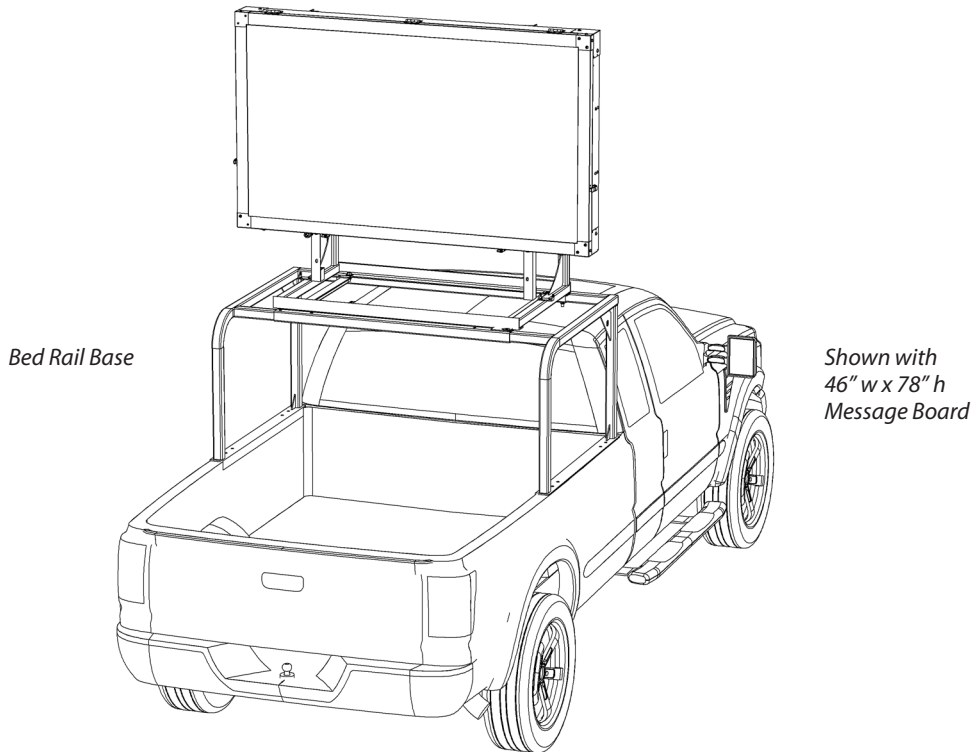

## Standard Equipment

- Manual winch and cable
- In-cab controller
- Power and control cables:  
20', 30' and 45' options

## Optional Equipment

- Powered pivot
- Wireless remote control
- Controller in battery box
- 50W, 100W or 150W solar arrays
- Auxiliary batteries (standard, Gel-Cell or AGM)
- Battery charger: 45 or 55 amp, 120 volt AC
- Vandal-proof battery box upgrades
- Radar

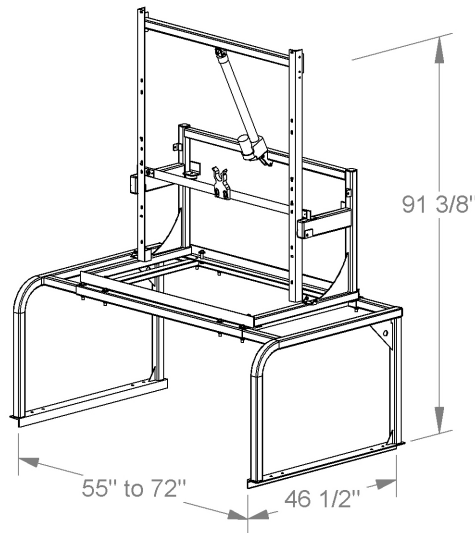

## Pivot Mount on Bed Rail Base

The Bed Rail Mount is used for pickup trucks, and is not mounted in the truck bed, allowing you full access to utilize the space.

The Pivot Mount allows the sign to fold horizontally behind the cab, allowing for an unobstructed view for the driver.

Sign sizes available for a Bed Rail Base configuration:

- 30" x 60" (2 Line)
- 30" x 60" (4 Line)
- 33" x 78" (2 Line)
- 38" x 92" (2 Line)
- 46" x 78" (3 Line)



Use our helpful **Vehicle Mount Configuration Guide** at [www.solartechnology.com](http://www.solartechnology.com)

Call your SolarTech sales rep  
or call 1-800-475-5442  
[www.solartechnology.com](http://www.solartechnology.com)

# Pivot Mount on Large Skid Base with MBIII Board

*Pivot Mount on  
Large skid base 49"  
high shown with  
optional battery box  
and optional solar  
arrays*

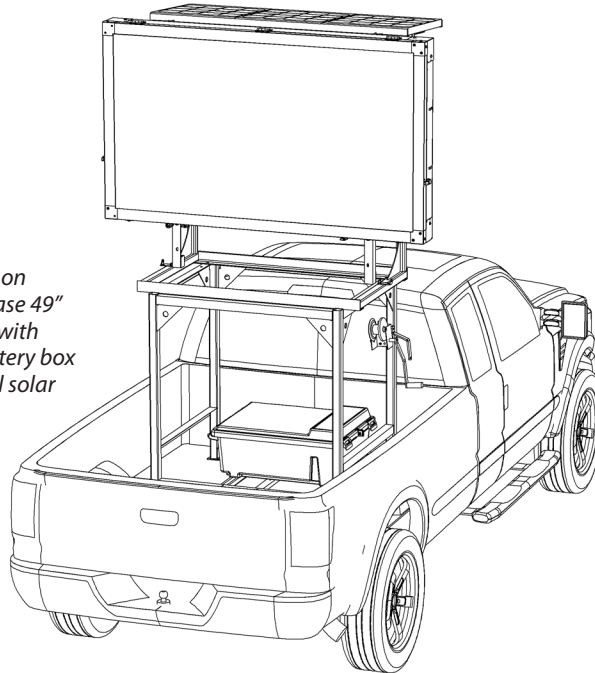

*Shown with  
46" w x 78" h  
Message Board*

## Standard Equipment

Manual winch and cable  
In-cab controller  
Power and control cables:  
20', 30' and 45' options

## Optional Equipment

Powered pivot  
Wireless remote control  
Controller in battery box  
50W, 100W or 150W solar arrays  
Auxiliary batteries (standard, Gel-Cell or AGM)  
Battery charger: 45 or 55 amp, 120 volt AC  
Vandal-proof battery box upgrades  
Radar

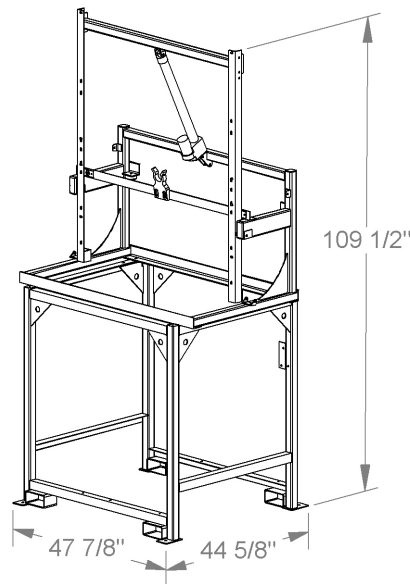

## Pivot Mount on Large Skid Base

Skid mounts are the most versatile mounts, and come in two standard heights, 18" and 49" high.

The Large Skid shown here can be fitted with a Pivot Mount, allowing the board to fold behind the cab for transport.

Battery box can be added to the base to power the sign.

### Message Board Sizes:

30" x 60" (2 Line)  
30" x 60" (4 Line)  
33" x 78" (2 Line)  
38" x 92" (2 Line)  
46" x 78" (3 Line)  
54" x 92" (3 Line)\*

\*Not available for Pickups/Utility Trucks



**A Better Board.**

Use our helpful **Vehicle Mount Configuration Guide** at [www.solartechology.com](http://www.solartechology.com)

Call your SolarTech sales rep  
or call 1-800-475-5442  
[www.solartechology.com](http://www.solartechology.com)

# Pivot Mount on Large Skid Base with MBIII Board

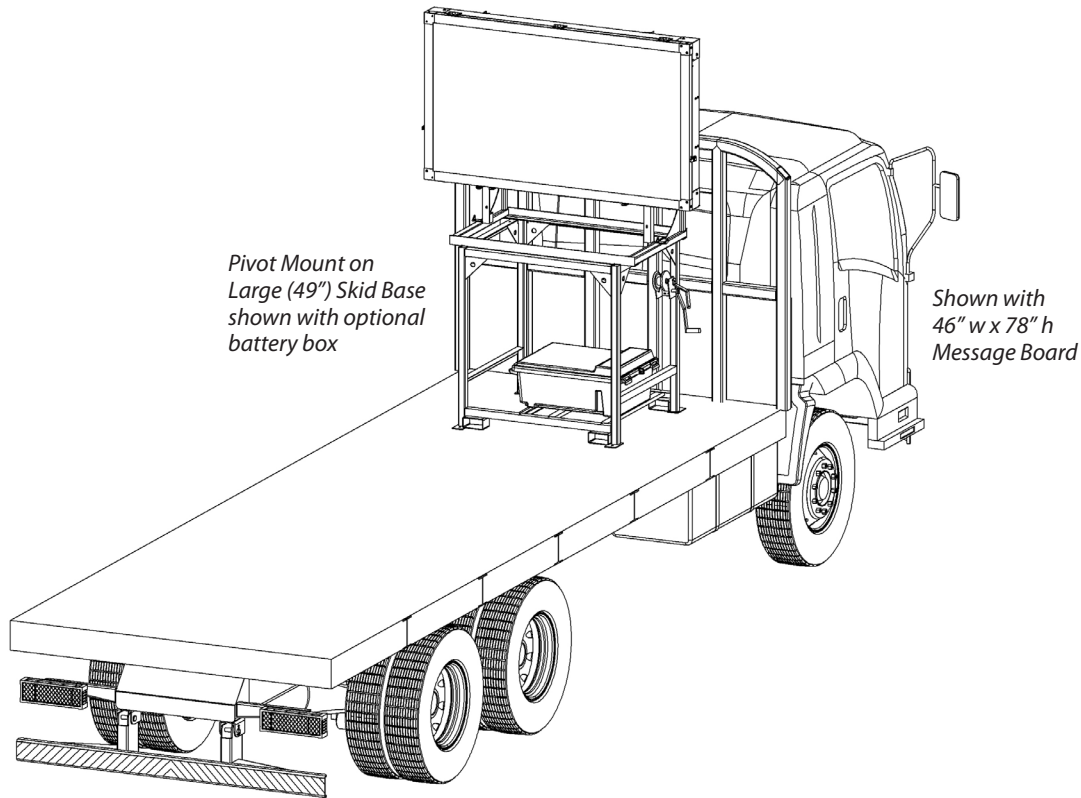

## Standard Equipment

- Manual winch and cable
- In-cab controller
- Power and control cables:  
20', 30' and 45' options

## Optional Equipment

- Powered pivot
- Wireless remote control
- Controller in battery box
- 50W, 100W or 150W solar arrays
- Auxiliary batteries (standard, Gel-Cell or AGM)
- Battery charger: 45 or 55 amp, 120 volt AC
- Vandal-proof battery box upgrades
- Radar

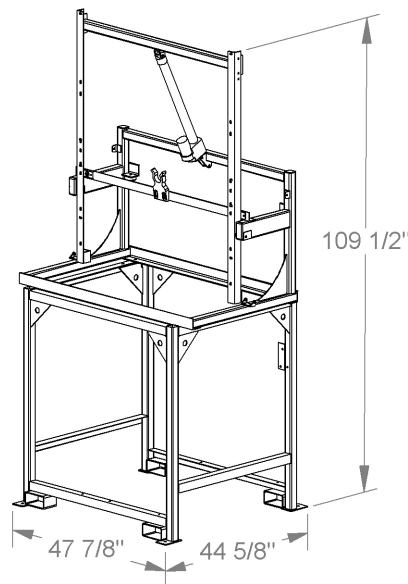

Pivot Mount on Large Skid

## Skid-Mount Base

The skid mounts are the most versatile, and come in two standard heights: Large (49" high) or Small (18" high). Skid Mounts can be placed anywhere and strapped or bolted in place, and can be used with any pivot mount. Battery boxes can be added to skid bases to power the board.

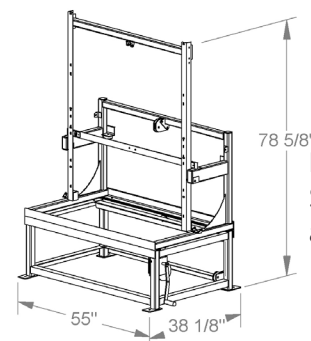

Pivot Mount on Small Skid also available



Use our helpful **Vehicle Mount Configuration Guide** at [www.solartechtechnology.com](http://www.solartechtechnology.com)

Call your SolarTech sales rep or call 1-800-475-5442

# Center Pivot Mount with MBIII Board

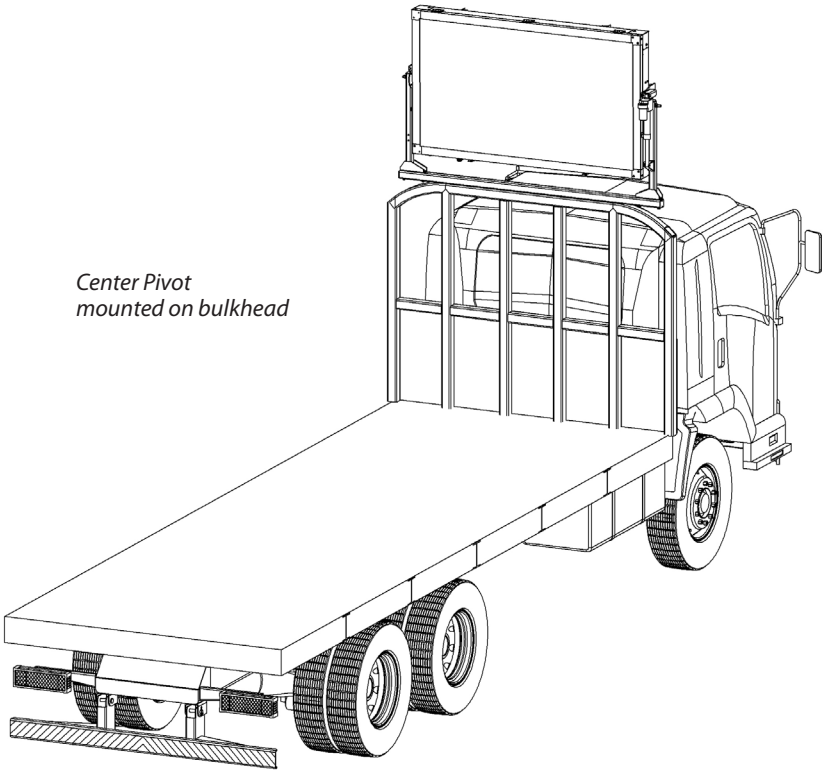

Center Pivot  
mounted on bulkhead

Shown with  
46" w x 78" h  
Message Board

## Standard Equipment

- Manual winch and cable
- In-cab controller
- Power and control cables:  
20', 30' or 45' options

## Optional Equipment

- Powered pivot
- Controller in battery box
- 50W, 100W or 150W solar arrays
- Auxiliary batteries (standard, Gel-Cell or AGM)
- Battery charger: 45 or 55 amp, 120 volt AC
- Vandal-proof battery box upgrades
- Radar

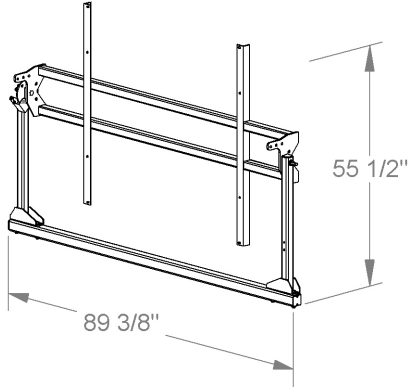

## Center Pivot Mount

The Center Pivot Mount shown here rotates the board around a center axis, allowing the board to tilt and lock horizontally for transport. Our most economical mount.

The Center Pivot Mount can be installed on any vehicle type in the following sign sizes:

- 30" x 60" (2 Line)
- 30" x 60" (4 Line)
- 33" x 78" (2 Line)
- 46" x 78" (3 Line)



A Better Board.

Use our helpful **Vehicle Mount Configuration Guide** at [www.solartechtechnology.com](http://www.solartechtechnology.com)

Call your SolarTech sales rep or call 1-800-475-5442  
[www.solartechtechnology.com](http://www.solartechtechnology.com)

# Universal Fixed Mount with MBIII Board

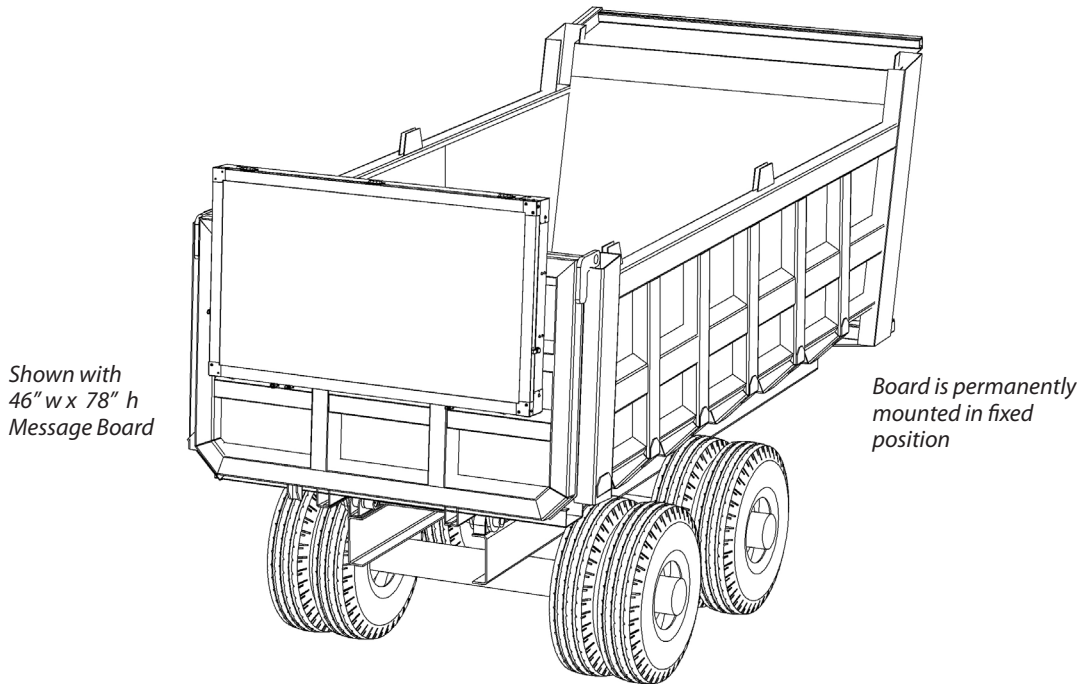

## Standard Equipment

Power and control cables  
20', 30', or 45' options

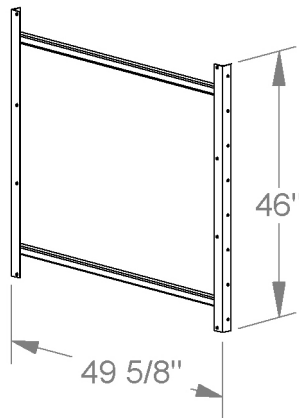

## Universal Fixed Mount

The Universal Fixed Mount permanently attaches a board to a flat surface without pivoting or rotating. Often used on dump trucks or other large vehicles, the Universal Fixed Mount can support signs of any size.

Available sign sizes:

- 30" x 60" (2 Line)
- 30" x 60" (4 Line)
- 33" x 78" (2 Line)
- 38" x 92" (2 Line)
- 46" x 78" (3 Line)
- 54" x 92" (3 Line)\*

\* Not available for Pickup/Utility Trucks



**A Better Board.**

2021 Rev. A

Use our helpful **Vehicle Mount Configuration Guide** at  
[www.solartechology.com](http://www.solartechology.com)

Call your SolarTech sales rep  
or call 1-800-475-5442  
[www.solartechology.com](http://www.solartechology.com)